

35 sheets, Sheet 1.

T. L. Hawkins,

Making Fellies.

N<sup>o</sup> 23,840.

Patented May 3, 1859.

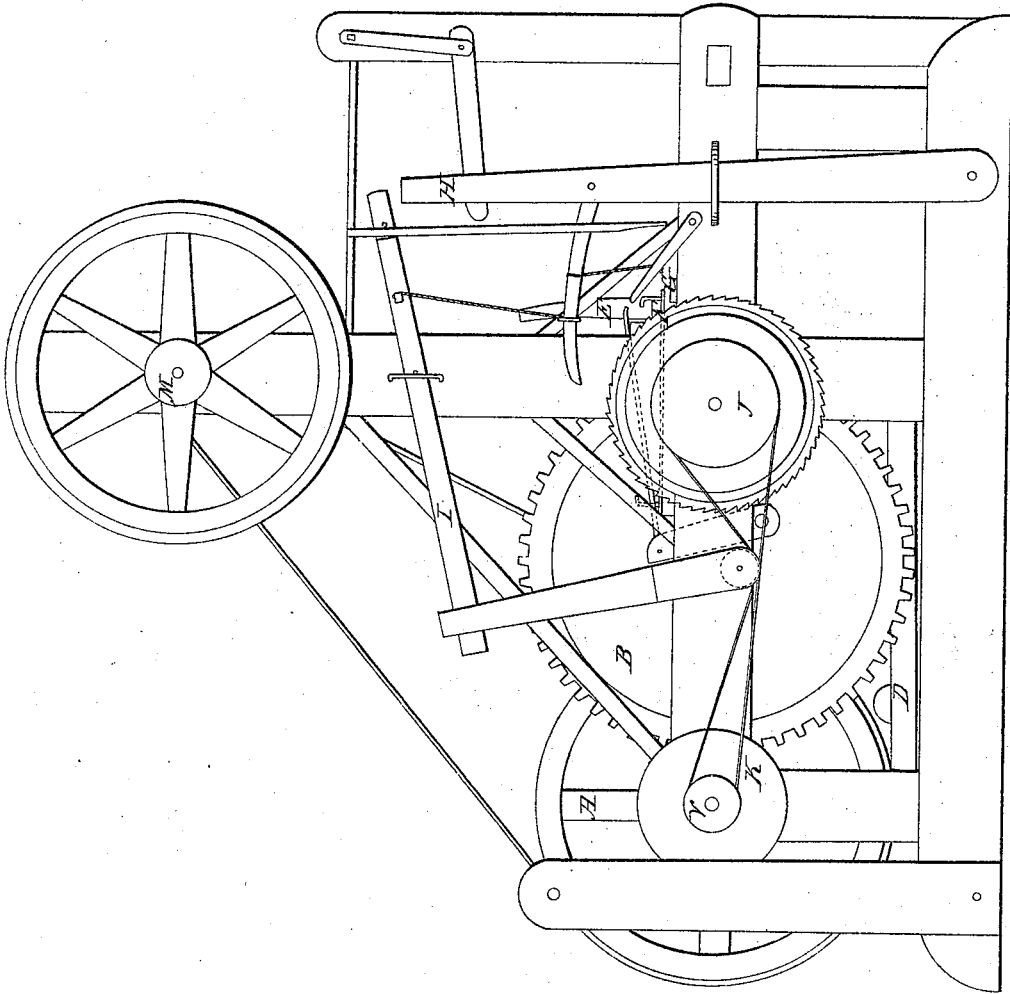

Witnesses.

E. J. Hill  
P. H. Taylor

Inventor.

Thos. L. Hawkins

T.L. Hankins,

Making Fellies.

N<sup>o</sup> 23,840.

Patented May 3, 1859.

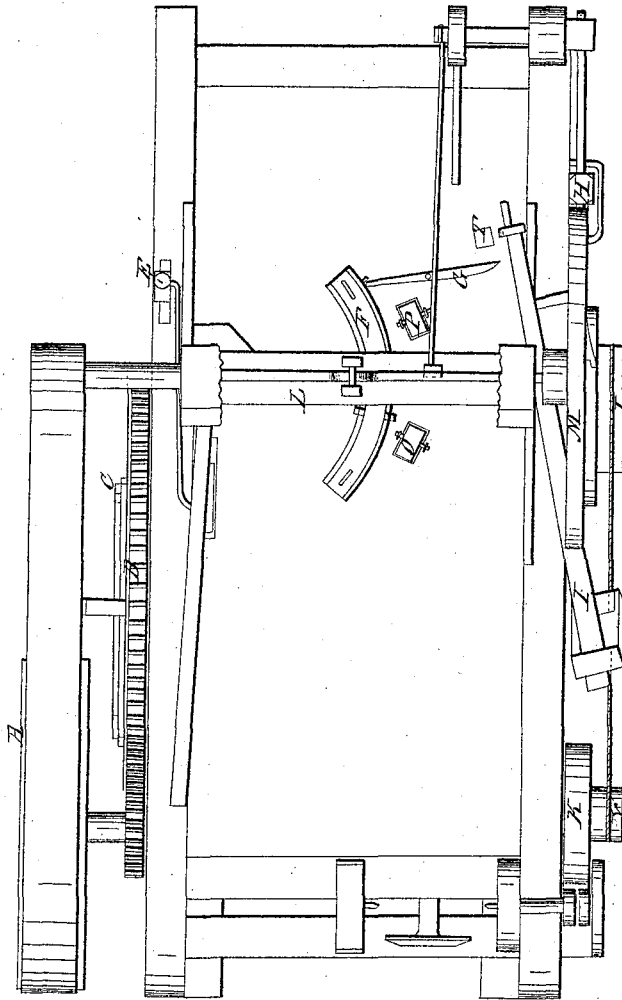

Witnesses:  
E. J. Hill  
P. G. Taylor

Inventor:  
Thos. S. Hawtorn

T. L. Hawkins,  
Making Fellies.

N<sup>o</sup> 23,340.

Patented May 3, 1859.

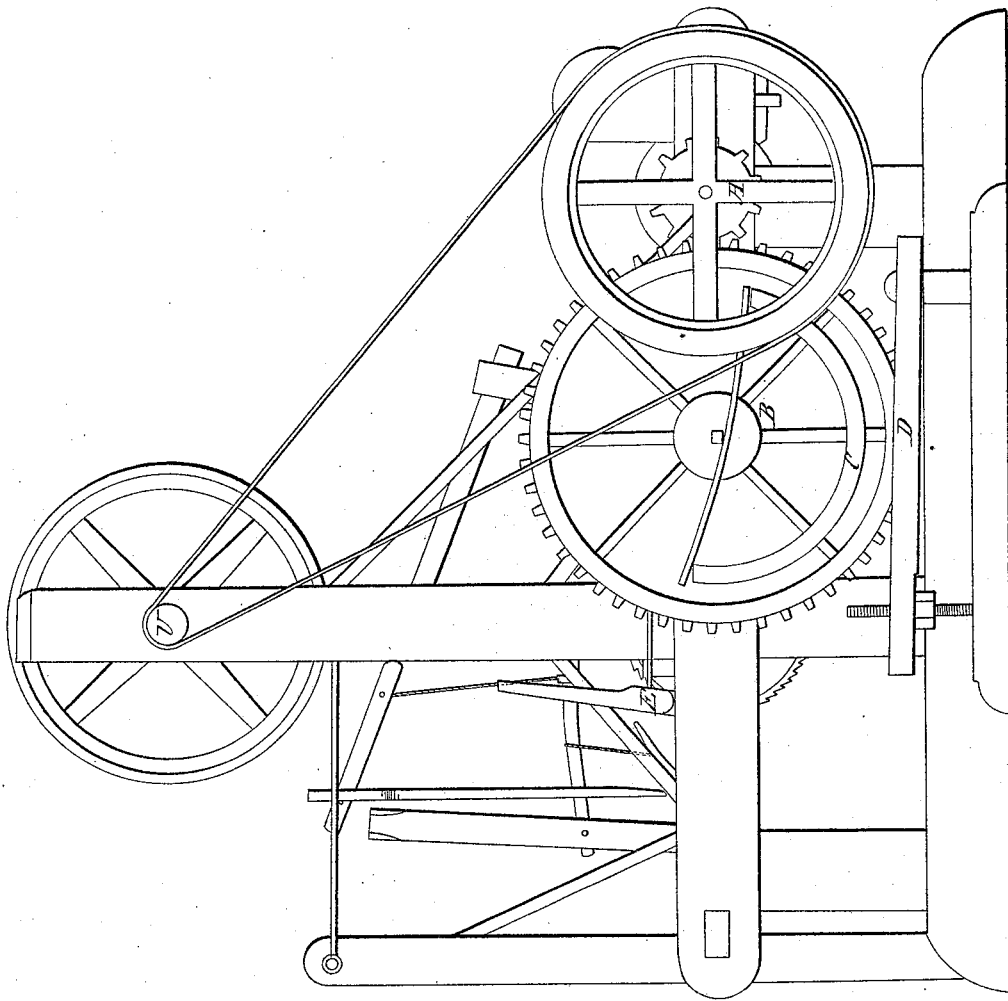

Witnesses

E. J. Hill  
D. H. Taylor

Inventor

Thos. L. Hawkins

# UNITED STATES PATENT OFFICE.

THOMAS L. HAWKINS, OF STURGEON, MISSOURI.

## WHEELWRIGHT'S MACHINE.

Specification of Letters Patent No. 23,840, dated May 3, 1859.

*To all whom it may concern:*

Be it known that I, THOS. L. HAWKINS, of Sturgeon, Boone county, State of Missouri, have invented a new and useful Improvement in Felly-Machines, &c.; and I do hereby declare that the following is a full, clear, and exact description of the construction and operation of the same.

I now refer you to the model of my machine. In the first place I will begin with the letter A. (A) the drum or master wheel of the machine. This can be run by steam or horse power by a tumbling shaft or wallower being attached thereto. (B) the bending wheel. This is to be a cast iron wheel; (C), a half circle. This can be made of two or three different sizes or as many as the mechanic may wish. This half circle must be attached to the wheel by bolts through the spokes. The revolution of the bending wheel B with the cogs on its rim brings the half circle C over the roller (D) which presses the felly between the two and forms the timber into a half circle which can be nailed to the piece of timber at each end as you see in the wheel and hence (E) is the lever which throws the bending wheel in and out of gear as is required when the drum A is thrown into action the band that runs over the pulley (U) which throws into action the cutter head or sash (L) which is connected with the lever (H) and its oper-

ators which gives a revolution to the rag wheel (I). This wheel is connected to a small cog wheel which moves the carriage or pattern (F). This pattern with its rollers (O P) moves the timber to the saw or cutter head (L) until the knob on pattern F comes in contact with the spring (G) which throws the balance (I) from its catch in the floor or hole (T). This balance I as soon drops from its catch falls on the cross band from (V) to (I) and at the same time lifts the catches from the rag wheel (I) and sends the carriage F back to its proper place.

This machine with its fly wheel (M) gives the saw or cutter head L power to drive through most any kind of timber.

The wheel (K) is designed to run the lathe (N). This lathe is used expressly for the wagon manufacturer for turning hubs, &c. This lathe is run by a band running from the wheel (K) over the pulley or whirl of the lathe. There is two head blocks are stationary that holds the whirl while the other as adjustable.

What I claim in this machine is—

The arrangement of the several parts substantially as described for the purpose set forth.

THOS. L. HAWKINS.

Witnesses:

S. M. RIGGS,  
J. S. PARMER.